



Project: Beaver T. Tremblant

Item Number: EQ1

Quantity: 1

CAYENNE® MEDIUM-DUTY FLAT TOP ELECTRIC GRIDDLES



Cayenne® Electric Griddle - Model 40716

DESCRIPTION

Vollrath Cayenne® Electric Griddles are portable and compact. They serve up the best steaks, chops, burgers, mixed grills, seafood and pancakes. They are ideal for breakfast, lunch and dinner. The 120V unit is ideal for caterers and breakfast buffets or brunches.

Ideal for use in steak houses, restaurants, coffee shops, clubs and pubs. Vollrath electric griddles are portable and compact for outside caterers.

CLEARANCE AND POSITIONING

This appliance must be installed with a minimum clearance of 6" (15.2 cm) between the left, right and back sides, and any combustible surface. The supplied 4" (10.2 cm) legs must be installed and the unit placed on a non-combustible surface.

MODELS

- 40715 FTA7016 14" Flat Top Electric Griddle
- 40716 FTA8024 24" Flat Top Electric Griddle
- 40717 FTA3086 36" Flat Top Electric Griddle

FEATURES

- Superior element design ensures even heating over entire cooking surface
- Fast startup and recovery times
- Heavy-duty polished cooking surface for high heat retention
- Griddle plate is fully welded to base
- Knob guards protect against accidental changes or damage
- Internally-mounted grease collection pan for cleaner appearance and easier cleaning and maintenance
- 120V, 14" unit (40715) is ideally sized for buffet, brunch, or catering applications
- 36" (40717) model features independent controls per 12" heating zone, creating multiple stations in one unit
- Snap-action thermostat provides accurate temperature control
- Heavy-duty adjustable legs
- 3 ft. (91.4 cm) cord with plug

WARRANTY: All models shown come with Vollrath's standard warranty against defects in materials and workmanship. For full warranty details, please refer to the Vollrath Equipment and Smallwares Catalog.

Agency Listings



Due to continued product improvement, please consult www.vollrathco.com for current product specifications.

Approvals	Date



Setting the Standard™

www.vollrathco.com

The Vollrath Company, L.L.C.
 1236 North 18th Street
 Sheboygan, WI 53081-3201 U.S.A.
 Customer Service: 800.628.0830
 Canada Customer Service: 800.695.8560
 Main Fax: 800.752.5620 or 920.459.6573

Technical Services: 800.628.0832
 Technical Services Fax: 920.459.5462

CAYENNE® MEDIUM-DUTY FLAT TOP ELECTRIC GRIDDLES

MODELS	40715	FTA7016	14" Flat Top Electric Griddle
	40716	FTA8024	24" Flat Top Electric Griddle
	40717	FTA3086	36" Flat Top Electric Griddle

DIMENSIONS

☐ Dimensions shown in inches (cm).

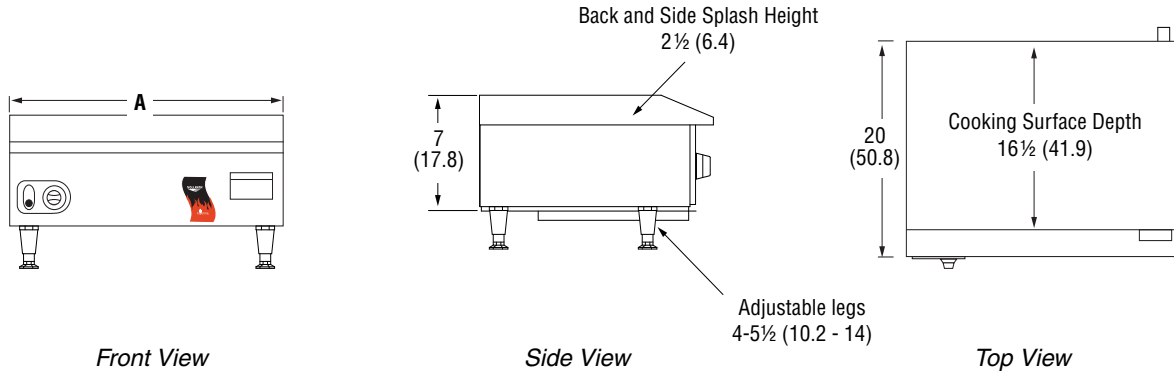

SPECIFICATIONS

Item	(A) Width	Number of Controls	Watts	Volts	Amps	Ship Weight Lb (Kg)	Plug
40715	14¼ (36.2)	1	1800	120	15.0	49 (22.2)	5-15P
40716	24 (61.0)	1	3000	220*	13.6	78 (35.4)	6-15P
40717	36 (91.4)	3	8400	220*	38.0	110 (49.9)	6-50P

*Single Phase

Receptacles

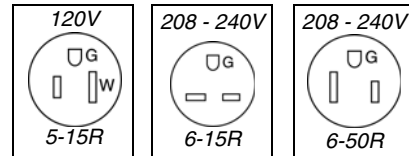

www.vollrathco.com

The Vollrath Company, L.L.C.
 1236 North 18th Street
 Sheboygan, WI 53081-3201 U.S.A.
 Customer Service: 800.628.0830
 Canada Customer Service: 800.695.8560
 Main Fax: 800.752.5620 or 920.459.6573

Technical Services: 800.628.0832
 Technical Services Fax: 920.459.5462