

Model Numbers

IR-4	IR-G24
IR-4-XB	IR-G24-XB
IR-2-G12	IR-4-SU
IR-2-G12-XB	IR-4-SU-XB

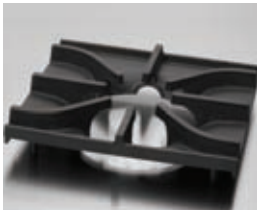

Two rings of flame for even cooking no matter the pan size.



Front grate with anti-clogging pilot shield protects the pilot from grease and debris.



Back grate hot air dam deflects heat onto the stock pot, not the backslash.



Large 5" (127 mm) stainless steel landing ledge for convenient plating.



Durable cast aluminum with a vylox heat protection grip.



IR-4 shown with optional casters

OPEN BURNERS - PyroCentric™ 32,000 BTU (9 KW) anti-clogging burner with a 7,000 BTU/hr. (2 KW) low simmer feature. Two rings of flame for even heating.

- Cast iron PyroCentric burners are standard on all IR Series Ranges.
- Burners are anti-clogging and lift-off and separate for easy cleaning. No gaskets or screws.
- One standing pilot per burner for instant ignition.

GRATES - Front grates measure 12" x 11" (305 x 279 mm). Back grates are 12" x 13" (305 x 330 mm).

- Back grates are sized for positioning large stock pots directly over burner and feature a hot air dam.
- Pots slide easily from section to section and onto landing ledge.
- Grates are cast iron for a long service life.

GRIDDLE - highly polished 3/4" (19 mm) steel plate. 21" (533 mm) plate depth.

- Burners have 20,000 (6 KW) BTU/hr. output with a heat deflector every 12" (305) for even heating.
- 3" (76 mm) wide grease trough and removable grease can for easy cleaning.
- Large griddle grease can and full width broiler drip tray are removable for easy cleaning.



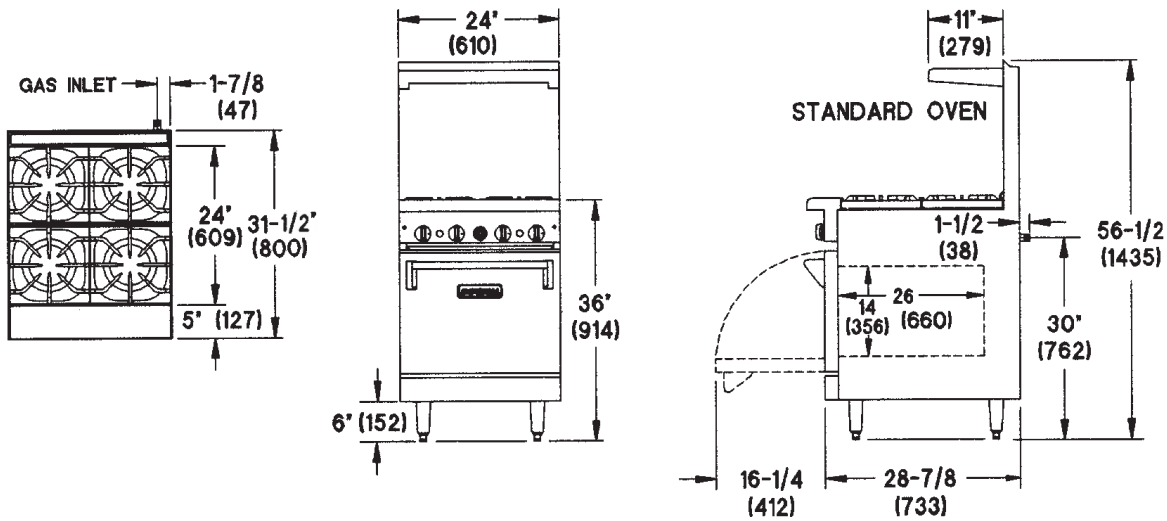

STANDARD SPACE SAVER OVEN - Linear burner provides even heating throughout the 27,000 BTU/hr (8 KW) oven. 100% safety pilot.

- Unique burner baffle distributes heat flow to provide even temperatures throughout the oven cavity.
- Exclusive heat deflector reflects heat into the oven, not the floor.
- Interior is 20" w x 26" d x 14" h (508 w x 660 d x 356 h mm). Accommodates standard size sheet pans.
- Porcelainized sides, rear, deck and door lining for easy cleaning. Heavy duty door hinge.
- Stamped inner door liner provides extra strength while optimizing heat retention.
- One chrome oven rack is included.





24" RESTAURANT RANGES

TOP	MODEL	GAS OUTPUT BTU	(KW)	OPEN BURNERS	GRIDDLE WIDTH	SHIP WEIGHT (KW)	LBS
	IR-4	155,000	(45)	4	N/A	(210)	465
	IR-4-XB	128,000	(38)	4	N/A	(183)	405
	IR-2-G12	111,000	(33)	2	12" (305 mm)	(213)	470
	IR-2-G12-XB	84,000	(25)	2	12" (305mm)	(185)	410
	IR-G24	67,000	(20)	N/A	24" (610 mm)	(224)	495
	IR-G24-XB	40,000	(12)	N/A	24" (610 mm)	(196)	435
	IR-4-SU	155,000	(45)	4	N/A	(210)	465
	IR-4-SU-XB	128,000	(38)	4	N/A	(183)	405

Measurements in () are metric equivalents.

NOTES

- "XB" specifies Cabinet Base
- "G" specifies Griddle Top
- "SU" specifies Step-up

EXTERIOR

- Stainless steel front, sides, backguard, shelf, landing ledge and kick plate
- Welded and polished stainless steel seams
- Large 5" (127 mm) stainless steel landing ledge
- Control knobs are durable cast aluminum with a vylox heat protection grip
- Full width, removable crumb tray for easy cleaning
- 6" (152 mm) heavy duty legs with adjustable feet
- One year parts and labor warranty

OVERALL DIMENSIONS	CRATED DIMENSIONS
24" w x 31-1/2" d x 36" h* (610 x 800 x 914 mm)	26-1/2" w x 39" d x 35"*** h (673 x 991 x 889 mm)

* to cooktop

** add 4" (102 mm) for Step-up models

MANIFOLD PRESSURE NATURAL GAS	MANIFOLD PRESSURE PROPANE GAS	MANIFOLD SIZE
5.0" W.C.	10.0" W.C.	3/4" (19 mm)

Specify type of gas and elevation, if over 2,000 ft.

CLEARANCE REQUIREMENTS

For use only on non-combustible floors. Legs or casters are required for non-combustible floors; or 2" (51 mm) overhang is required when curb mounted. Provide 0" clearance from non-combustible surfaces and 8" (203 mm) from combustible surfaces.

OPTIONS AND ACCESSORIES

- Reinforcement channels for mounting cheese melter/salamander
- 10" (254 mm) stainless steel wok ring
- Saute burner head, interchangeable
- Wok burner head, interchangeable
- Extra oven racks
- Thermostatic griddle control (specify griddle size)
- Grooved griddle top
- Chrome griddle top
- Griddle safety valve
- Gas shut off valve 3/4" (19 mm)
- Quick disconnect and flexible gas hose
- 6" (152 mm) casters

