

**OPERATION MANUAL
FOR**

Robot*  *Coupe[®]

MODELS

**R2N and R2N Ultra
(3 Quart)**

Also includes the submodels
R2 B, R2 C, and R2 Ultra B within the
following serial number groups:

246xxxxx03

247xxxxx03

robot coupe U.S.A., Inc.
P.O. Box 16625, Jackson, MS 39236-6625
280 South Perkins St., Ridgeland, MS 39157
email: info@robotcoupeusa.com
website: www.robotcoupeusa.com
1-800-824-1646

Phone: 1-800-824-1646
 Fax: 601-898-9134
 email: info@robotcoupeusa.com

These plates are for the following machines:

R100, R2N, R2N Ultra, R300, R301 Ultra, R302, R302V, and the CL30.

<u>Waved Slicing Plates</u>	<u>Size</u>
R212.....	2MM.....5/64

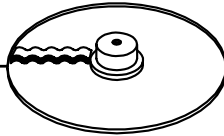
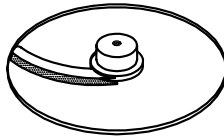

<u>Slicing Plates</u>	<u>Size</u>
R291.....	1MM.....1/32
R210.....	2MM.....5/64
R292.....	3MM.....1/8
R211.....	4MM.....5/32
R293.....	5MM.....3/16
R270.....	6MM.....1/4

<u>Grating Plates</u>	<u>Size</u>
R271.....	Hard Cheese
R294.....	Ex Fine .7MM .02
R295.....	Ex Fine 1MM.....1/32
R208.....	1.5MM.....1/16
R209.....	2MM.....5/64
R281.....	3MM.....1/8
R280.....	6MM.....1/4
R215.....	9MM.....3/8

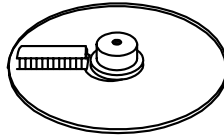

<u>Julienne Plates</u>	<u>Size</u>
R214.....	2x2MM.....5/64x5/64
R296.....	2x4MM.....5/64x5/32
R288.....	4x4MM.....5/32x5/32
R297.....	2x6MM.....5/64x1/4
R213.....	6x6MM.....1/4x1/4
R298.....	8x8MM.....5/16x5/16

INTRODUCTION

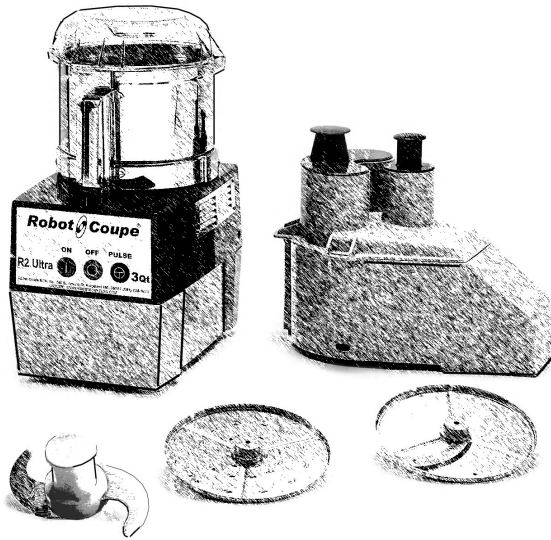

The Robot Coupe commercial food processor performs a host of culinary feats. It is designed for high speed and quality vegetable processing. The Robot Coupe *slices, juliennes, and shreds* with the continuous feed attachment, plus it will *chop, grind, puree, mix, or knead* using the cutter bowl attachment.

This operators manual is broken down into sections giving you detailed instructions for assembly and operation of the continuous feed attachment and the cutter bowl attachment. Close attention should be paid to all instructions in this manual to ensure a long life utilization of your food processor.

This manual should be kept within easy access to all users for reference, and should be read completely by all first time users of the machine.

Maintaining the food processor in good working condition is one of the most important measures to be taken. Inspect the machine and all parts regularly to make sure they are in good working condition.

DO NOT operate a machine that has malfunctioned in any way.

Discard any food processed at the time of a malfunction and have the machine inspected and repaired at one of the Robot Coupe Authorized Service Agencies, a list is provided in the back of this manual. Contact one of these service agencies for all of your service, parts and accessory requirements.

CAUTION: Your Robot Coupe comes with a sharp cutting “S” blade and cutting plates. Always handle with safety in mind. We suggest that a pair of cut-resistant gloves be worn when handling the “S” blade and plates.

Machine Specifications:

The Models R2N and R2N Ultra are equipped with a high speed motor generating 1/2 Hp which plugs into a standard 120 volt/ 60 Hz, 15 amp power outlet. The full load amperage rating is 7 amps. The machines are supplied with a 3 Quart bowl. The R2N has a plastic bowl, and the R2N Ultra has a metal bowl. The machines are supplied with an S-blade and a clear plastic cover, a continuous feed assembly, and two cutting plates. The machines are equipped with push type on/off/pulse buttons.

- I. INTRODUCTION
- II. ASSEMBLY/DISASSEMBLY INSTRUCTIONS
- III. OPERATING INSTRUCTIONS
- IV. PREVENTIVE MAINTENANCE GUIDE
- V. TROUBLE SHOOTING AIDS
- VI. SERVICE AGENCY LISTING

II. ASSEMBLY/DISASSEMBLY INSTRUCTIONS

Your Robot Coupe should be placed on a sturdy work surface at a comfortable working height and have a standard 115 volt power outlet available. Always keep the machine unplugged during assembly and disassembly.

A. CUTTER BOWL ATTACHMENT ASSEMBLY INSTRUCTIONS

Always use caution, and wear cut-resistant gloves when handling the blade or the cutting plates.

Always unplug the machine during assembly and disassembly.

1. **Unplug the machine.**
2. Place the bowl on the motor base assembly with the handle located just off center and to the left as you are facing the front of the unit. Then, turn the bowl back counterclockwise locking it in place.
3. Place the blade on the motor shaft. Rotate the blade until it falls into place on the motor shaft. The bottom blade should be just off, and parallel with, the bottom of the bowl.
4. **Press the off button in case the machine was left turned on.**
5. Facing the front of the motor base assembly, place the lid on the bowl with the ramp turned off center and to the left.
6. Turn the ramp back to the right until it locks in place over the safety switch rod.

7. DO NOT OPERATE THE MACHINE UNLESS IT IS PROPERLY ASSEMBLED WITH THE LID CENTERED OVER THE BOWL AND THE RAMP LOCKED IN PLACE OVER THE SAFETY SWITCH ROD!

8. ALWAYS REMOVE THE BOWL LID BEFORE ATTEMPTING TO REMOVE THE BOWL. OTHERWISE, THE SAFETY PIN CAN BE BROKEN, PREVENTING MACHINE OPERATION.

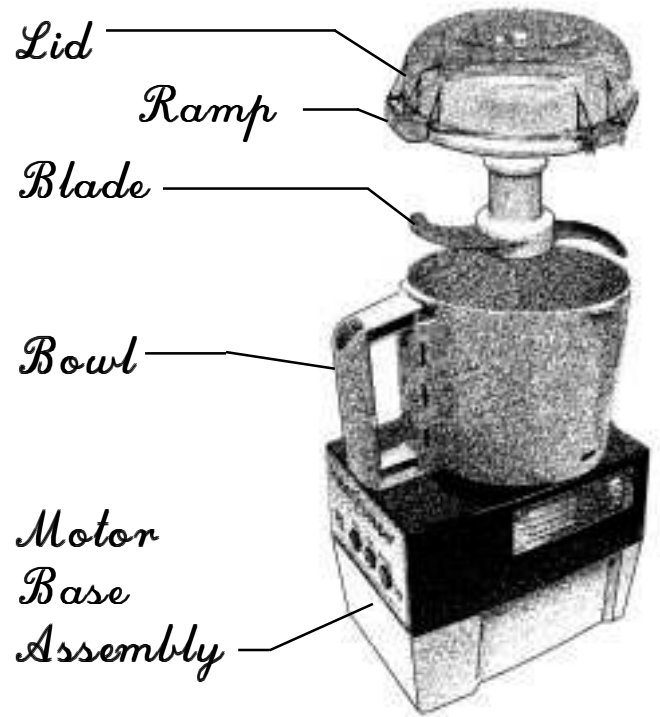

B. CONTINUOUS FEED ATTACHMENT ASSEMBLY INSTRUCTIONS

1. THE CORD SHOULD ALWAYS BE UNPLUGGED DURING ASSEMBLY AND DISASSEMBLY!

2. Place the continuous feed attachment on the motor base with the discharge chute to the back (as you are facing the front of the motor base).

3. Looking from the top, turn the attachment slightly clockwise, and with a gentle downward pressure, turn it back counterclockwise; until it locks into place. The attachment should be level with the top surface of the motor base.

4. Place the plastic discharge plate on the motor shaft, and rotate the plate until it drops fully into place on the motor shaft. When properly installed, it should be level with and just off the bottom of the continuous feed attachment.

5. Place the cutting plate of your choice on the discharge plate. Rotate the plate until it drops into place and is fully seated on the discharge plate.

6. Press the off button in case the machine was left turned on.

7. Facing the front of the motor base assembly, place the continuous feed lead on the continuous feed attachment with the ramp on the lead aligned over the safety switch rod on the continuous feed attachment. While looking down at the top, turn the lead slightly clockwise then back counterclockwise, locking it in place. The lead should be aligned with the top surface of the continuous feed attachment.

8. Place the pushers in their corresponding openings in the continuous feed lead.

9. DO NOT OPERATE THE MACHINE UNLESS IT IS PROPERLY ASSEMBLED AND THE CONTINUOUS FEED LEAD IS FULLY SEATED AND CENTERED OVER THE ATTACHMENT!

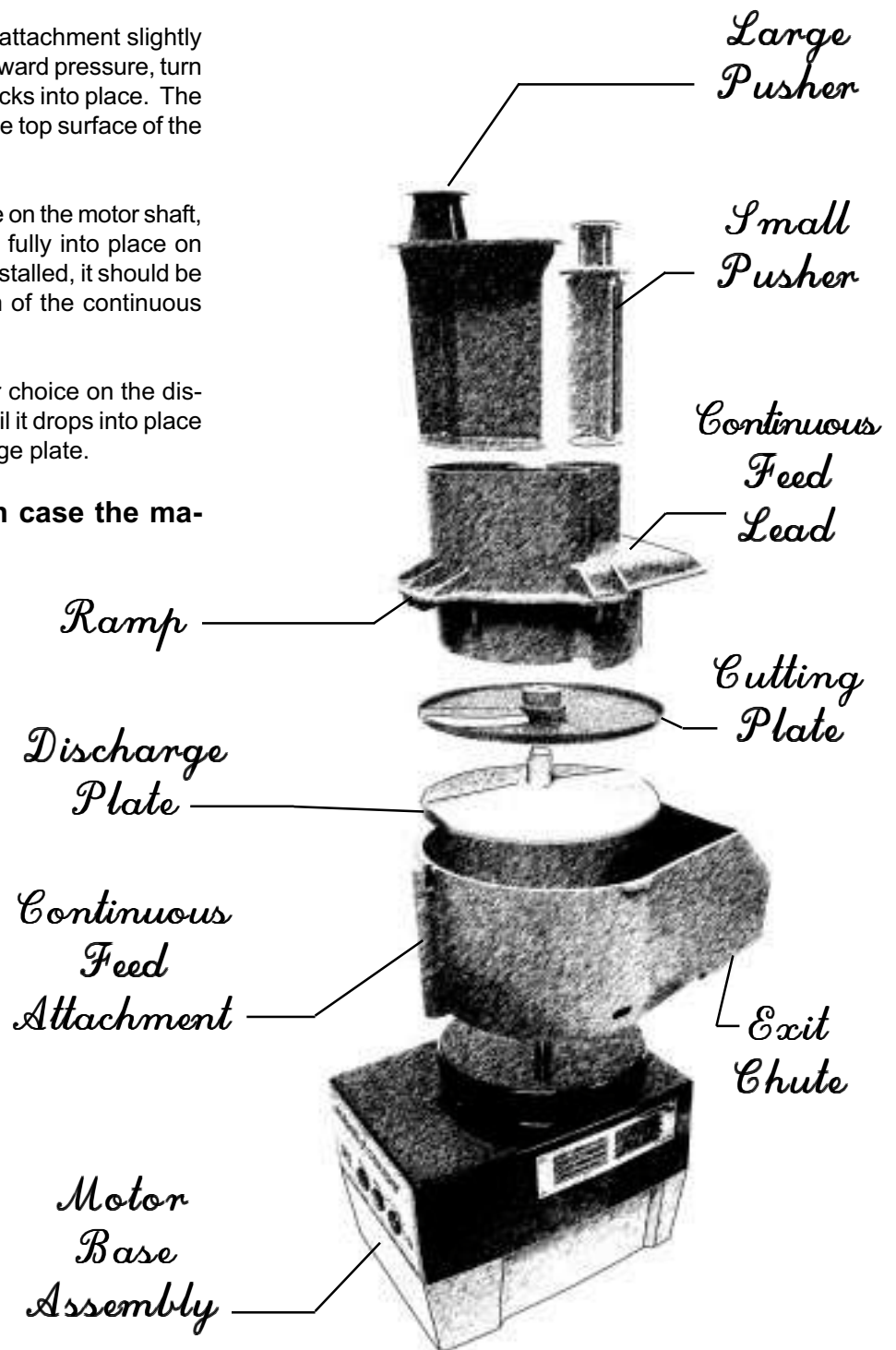

The continuous feed lead, with the pushers in place, provides protection from the cutting plate. When the lead is turned to its closed position with the ramp in place over the pin, a safety switch is activated, and the machine can be turned on and off by use of the push buttons. If the lead is not in the closed position, the buttons will not function.

NEVER ATTEMPT TO DEFEAT THE PURPOSE OF THE SAFETY SWITCH MECHANISM.

ALWAYS USE THE OFF AND ON BUTTONS TO OPERATE THE MACHINE.

The Food Processor is now assembled and ready to perform its desired function.

BEFORE CONTINUING YOU SHOULD COMPLETELY READ THE INSTRUCTIONS CONTAINED IN THIS MANUAL.

The continuous feed lead has two feed openings, one large and one small, with matching pushers. The food is inserted in the chosen opening by removing the pusher with one hand and then depositing the food into the chute with the other hand. The pusher should then be used to push the food through the opening.

DISASSEMBLY INSTRUCTIONS: Simply reverse the steps outlined in the assembly instructions with the power cord unplugged from its wall socket.

ALWAYS REMOVE THE CONTINUOUS FEED LEAD BEFORE REMOVING THE CONTINUOUS FEED ATTACHMENT. OTHERWISE, THE SAFETY PIN CAN BE BROKEN, PREVENTING MACHINE OPERATION.

III. OPERATING INSTRUCTIONS

THE UNIT SHOULD BE OFF EXCEPT WHEN PROCESSING IS UNDERWAY.

It is recommended that the machine be operated on a 50% duty cycle. This is easily accomplished since the preparation time (cleaning, coring, peeling, and loading) takes longer than the processing time. This will yield the longest life for your machine.

NOTE: This machine is equipped with manual reset thermal overload protection. If the machine is overloaded or run too long under heavy load conditions, the overload will trip. If this occurs, first remove the bowl and reduce the amount of food being processed. The reset button is located on the bottom of the motor base. Press the button in to reset the overload protector.

DO NOT ALLOW THE MACHINE TO RUN UNATTENDED.

A. INSTRUCTIONS FOR USE OF THE CUTTER BOWL

The cutter bowl attachment is used for grinding, pureeing, blending, mixing, of ingredients. With the power switch off and the bowl and blade secured in place (per previous instructions), you are now ready to add product to the bowl. There are two ways to run your machine. Chopping, using a quick start/stop action with the pulse button, or running continuously for a fine chop or puree.

1. TO CHOP

To achieve a chopped consistency for vegetables, meats, cheese, etc., fill the bowl 2/3 to 3/4 full with portions no larger than 1 to 2 inch square. Press the pulse button until the desired consistency is reached. If the motor stalls, reduce the amount of product in the bowl.

2. TO PUREE OR FINE CHOP: For a fine puree, emulsification, or fine chop, fill the bowl 2/3 to 3/4 full with portions no larger than 1 to 1 1/2 inches square. Begin by pulsing the machine to reduce the size then, press the on button, and allow the machine to run until the product is finely chopped or pureed. Some purees may require the addition of a liquid to obtain the correct consistency.

3. TO CHOP HARD CHEESE: Place uniform 1" to 1 1/2" cubes of chilled cheese up to 1 1/2 pounds into the bowl and pulse the machine. For powdered cheese pulse the motor until the cheese is about pea size then allow the motor to run continuously until you

3. TO CHOP HARD CHEESE: Place uniform 1" to 1 1/2" cubes of chilled cheese up to 1 1/2 pounds into the bowl and pulse the machine. For powdered cheese pulse the motor until the cheese is about pea size then allow the motor to run continuously until you have a fine powder.

4. TO CHOP ONIONS, CELERY, CABBAGE, ETC. Quarter onions, and cut other vegetables into 2 to 3 inch portions. Place the product into the bowl up to 3/4 full and pulse the unit until you reach the desired consistency. **CAUTION:** If you overfill or allow the machine to run continually, the product on the top may not be cut while that on the bottom will be pureed.

5. TO PUREE OR MIX: To puree, make sauces, or to mix and blend, place the ingredients into the bowl (do not overfill), turn the unit on, and allow to run continuously.

Sharpening the "S" blade

The "S" blade will require sharpening on a periodic basis depending on use. The use of a dull blade will sometimes give unsatisfactory results. Follow the directions shown to sharpen the blade, or have the blades sharpened professionally if you prefer.

1. **Put on your cut-resistant gloves**
2. Use a Robot Coupe stone or any good sharpening stone.
3. Hold or clamp the blade flat on the edge or corner of a sturdy table.
4. With the other hand, hold the stone at a 30 degree angle against the top bevel of one blade.
5. Pull the stone into the blade edge moving from hub to tip, several strokes, until the blade is sharp.
6. Turn the blade over, and rub the stone flat against the underside of the blade to remove the feather edge formed at step 5.

7. Repeat the procedure for the other blade.
8. Wash the blade before use.

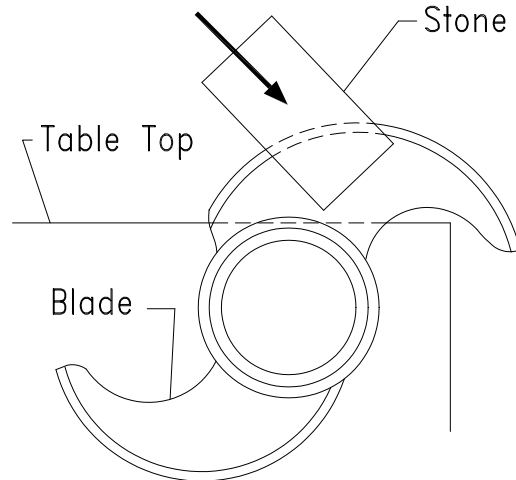

B: INSTRUCTIONS FOR USE OF THE CONTINUOUS FEED ATTACHMENT:

The Robot Coupe Food Processor will slice, grate, shred, and juliene. These processes will be performed in a matter of seconds. Because of the speed of the process, it is necessary that the operator perform preliminary steps before turning the machine on. Food preparation, feed chute loading, and availability of a receptacle for receiving the finished product are some of the steps to assure positive control of the processing operation.

Food preparation will be required to assure that the produce will fit a feed chute with the pusher covering the product. Additionally, according to personal preference, some products may or may not be cored or peeled. Feed chute selection should be made depending upon the product to be processed. As an example, good consistency of small round produce (carrots, cucumbers, etc.) necessitates use of the small feed chute to allow better operator control. Use of the larger port for this type of produce may result in an undesired finished product, e.g., slicing with the grain. In general, more control of the processing operation can also be obtained by filling the selected feed chute and placing the pusher in position before turning the machine on.

Adherence to certain operational techniques will also enhance the processing operation. For instance, a consistent pressure with the pusher upon the produce will yield a consistent output. Application of more pressure will increase the thickness of the product, e.g., thicker slice, while reduction in pressure will result in a finer product. However, do not apply enough pressure to stall or slow the motor. This will cause damage to both the plate and the motor. If no pressure is applied at all and the produce is permitted to bounce around, an inconsistent product may result. When the pusher has settled fully in the feed chute, press the off switch and re-load the entry port for a repeat process.

THE UNIT SHOULD BE OFF EXCEPT WHEN PROCESSING IS UNDERWAY. It is recommended that the machine be operated on a 50% duty cycle. This is easily accomplished since the preparation time (cleaning, coring, peeling, and loading) takes longer than the processing time. This will yield the longest life for your machine.

DO NOT remove the continuous feed lead when the motor is running. Wait until the motor has come to a full stop.

DO NOT attempt to run frozen products through the cutting plates.

DO NOT put anything other than food products in the feed chute.

Wear cut-resistant gloves when handling the cutting plates.

Keep hands out of the feed openings. Always use the food pushers.

(1) Slicing Operation: When preparing food to be sliced, make sure the food will fit into the proper feed chute. Produce such as carrots, cucumbers, etc., should be “squared” at both ends. This will provide a consistent slice throughout the whole product. With cabbage, lettuce or any product that has an undesirable core, the core should be removed. Medium size heads of lettuce or cabbage may be cut into thirds to fit the feed chute. It is also suggested that the rounded half be squared to permit a consistent cut. The rounded portion can be dropped into the chute at the end and with no pressure applied, it will normally be processed uniformly. Larger heads of cabbage or lettuce may be more effectively processed if they are cut into fourths. When the preparation has been accomplished, fill the selected feed chute, place the pusher in position, turn the machine on and observe the results.

(2) Grating Operation: Again, prepare the product as to allow insertion into the feed chute. Consider which chute will be used. As an example, placement of carrots horizontally in the large chute will result in a long grated product, while vertical insertion in the smaller chute will result in a short grated product. It is recommended that chilled cheese be used when grated cheese is desired, otherwise a gumminess may result. A fine coating of cornstarch applied to the cheese before grating will aid in keeping the finished product separated. A fine coating of cornstarch will not be visible and is tasteless. Grating cheese is one of the most trying processes and may cause overheating of the motor if not done in the recommended manner. It is recommended that a slight pulsating pressure be applied with the pusher while grating, alternating slight pressure on the pusher—no pressure—continuing in this manner until the block of cheese is completely grated. It is recommended that the cheese be prepared to fit the opening in volumes which will permit motor cool-down time during long production runs.

(3) Julienne Operation: Insertion of the product to be cut must be horizontal if a long stick is to be achieved, e.g., squash sticks. Vertical insertion will result in finely chopped products, e.g., chopped celery. A finely chopped onion product may also be obtained with this operation.

Plate Utilization

The Robot Coupe food processor will perform a variety of functions: slicing, grating, French fry, and julienne. There are a total of 25 different plates available to perform these functions to meet individual tastes. The 21 plates consists of:

- 7 slicing plates
- 8 grating plates
- 6 julienne plates

The standard Robot Coupe comes with two (2) plates. Check your most current price list for the plates which are included as standard. The number and type of plates will vary depending upon the use of the machine.

SLICING PLATES

The seven (7) slicing plates range from 1mm (approximately 3/64") to 6.5mm (approximately 1/4"):

Part Number	MM Slicing	Inches (Approx.)
R291	1mm	1/32 in.
R212	2mm(waved)	5/64 in.
R210	2mm	5/64 in.
R292	3mm	1/8 in.
R211	4mm	5/32 in.
R293	5mm	3/16 in.
R270	6mm	1/4 in.

Plate Usage

SLICING PLATES

R291 1/32" - 1mm Slicing Plate

The thinnest slicing plate is the R291. It is used for paper thin slicing of potatoes for potato chips. This plate will also slice carrots lengthwise which can be soaked in cold water to make flower petals for garnish.

R210 5/64" - 2mm Slicing Plate

The next to the thinnest of the straight slicing plates is the R210. It provides a wafer thin slice that makes harder vegetables look best. Carrots, radishes, celery and potatoes look terrific through this plate. This is the best plate for shredded lettuce for tacos and sandwiches. This is also the plate for cabbage for a German style slaw.

R292 1/8" - 3mm Slicing Plate

This is one of the new thickness of slice available. By cutting 1/8" thick it gives good shelf life and maximum yield. Almost any vegetable can be cut with this plate and gives greater yield than the standard slicer which comes with the unit.

R211 5/32" - 4mm Slicing Plate

The R211 is the best all purpose slicing plate. For most vegetables this thickness is best. Cucumbers, mushrooms, zucchini, and celery all cut beautifully with the R211 while providing a good shelf life. This is the second most popular plate requested and comes standard with the unit. Even soft foods like strawberries, bananas, and green onion tops slice marvelously.

R293 3/16" - 5mm Slicing Plate

Some foods are more attractive when sliced a bit thicker and that is the function of the R293. Half slices of tomato or bell pepper work good as well as yellow squash and zucchini. Try deep fried thick slices of potato using the R293 for home fries.

R270 1/4" - 6mm Slicing Plate

For soups and stews an extra thick slice is desirable. Carrots and celery work great this way. Any food that you want a more generous slice on will look terrific through the R270. For this reason it is the third most popular plate.

R212 5/64" - 2mm Waved Slicing Plate

This is a decorative, thin, waved slice. Harder vegetables will work best with this plate like carrots, radishes, zucchini and potatoes.

GRATING PLATES

There are eight grating plates available for use with the Robot Coupe:

Part Number	Metric	Inches (Approx.)
R271	Hard Cheese Grating	
R294	Extra Fine	.7mm .02 in
R295	Extra Fine	1mm 1/32 in.
R208	Fine	1.5mm 1/16 in.
R209	Medium	2mm 5/64 in.
R281	Medium Coarse	3mm 1/8 in
R280	Medium Coarse	6mm 1/4 in.
R215	Extra Coarse	9mm 3/8 in.

Plate Usage

GRATING PLATES

R271 Hard Cheese Grating Plate

The R271 is the plate which will make a powder from hard cheeses. Parmesan and Romano are used most extensively with this. When potatoes are run through this plate a batter is produced which is excellent for potato pancakes.

R294 .02"- .7mm Pulping Plate

The R294 pulping plate was created to grind Chinese radish into a pulp that is served with sushi. Moreover, it will render any vegetable into a wet pulp or batter, much the way a vegetable juicer does. This is ideal for vegetable sauces that are low fat.

R295 1/32"- 1mm Pulping Plate

The R295 reacts identically to the R294 but is just slightly coarser so that not as much juice is extracted. Use on ginger root (shoga), white radish (dikon), baby turnips (kabo), or lotus root (renkon).

R208 1/16" - 1.5mm Fine Grating Plate

The R208 is a delicate grate used mostly for cheeses and carrots. The width of the grate is 1/16" or 1.5mm. It also does an excellent job on bread crumbs and cold chocolate.

R209 5/64" - 2mm Medium Grating Plate

This is the most ordered plate of this series. While being used mainly for cheeses and carrots its size, 5/64" or 2mm, gives maximum yield with excellent shelf life. Also used on coconuts and potatoes for hash browns. This is the grating plate that comes standard with the unit.

R281 1/8" - 3mm Medium Coarse Grating

This new size grating plate is good for an extra fine coleslaw or anything you prefer grated a bit coarser than the standard R209 medium grating plate. This plate works wonderfully with cheese, potatoes, beets, eggs, cabbage or sweet potatoes.

R280 1/4" - 6mm Coarse Grating Plate

This in-between size of grate has become popular with salad bars. Cheeses and carrots appear a bit more generous when grated this way. Also purple cabbage run through this plate can add a splash of color to a salad bowl filled with lettuce.

R215 3/8 - 9mm Extra Coarse Grating Plate

The R215 is the widest grating plate. It provides an extra thick grate of cabbage for slaw and cheeses for melting. Mozzarella cheese looks terrific through the R215

JULIENNE PLATES

There are six julienne plates available:

Part Number	Metric	Inches (Approx.)
R214	2x2mm	5/64 x 5/64 in.
R296	2x4mm	5/64 x 5/32 in.
R288	4x4mm	5/32 x 5/32 in.
R297	2x6mm	5/64 x 1/4 in.
R213	6x6mm	1/4 x 1/4 in.
R298	8x8mm	5/16 x 5/16 in.

Plate Usage

JULIENNE PLATES

Products such as squash sticks, chopped celery, and finely chopped onions are obtainable as well as julienne celery

DO NOT ATTEMPT TO JULIENNE MEATS OR CHEESES.

R214 5/64 x 5/64 - 2 x 2mm Julienne Plate

The R214 is an extremely fine julienne which can dress up a salad. Radishes, potatoes, and carrots work best. Try julienne radishes with the R214 for an ultra-fine cut that looks like a top chef worked for hours preparing.

R296 5/64"x 5/32" - 2mm x 4mm Julienne Plate

This is an interesting flat julienne that gives substance to a delicate cut. One unique function of this plate is to duplicate the slaw cut that comes from a buffalo chopper. Try the R296 with radish, potato, summer squash, or sweet potato.

R288 5/32"x 5/32" - 4mm x 4mm Julienne Plate

This is the most popular of the julienne plates. Carrots, yellow squash, and zucchini work best. These can be sautéed and makes a beautiful garnish for an entree. Try steaming these too for a healthy and colorful side dish.

R297 5/64" x 1/4" - 2mm x 6mm Julienne Plate

This new julienne cut is becoming a very popular presentation on salads. Carrots, zucchini and yellow squash look especially good this way.

R213 1/4 x 1/4" or 6 x 6mm French Fry Plate

This might as well be called the taco plate. Tomatoes and onions can be quartered and allowed to gravity feed through the lead and are chopped without damage. Lettuce can be cut for a chopped taco lettuce. Chopped onions through the R213 are great for hot-dogs also. Every school system should have this plate. Bell peppers can be chopped like the onions for meatloaf or chili. As a sideline the French fry plate makes great French fries and is the fifth most popular plate.

R298 5/16" x 5/16" or 8mm x 8mm Julienne Plate

The 8 x 8mm julienne plate is great for zucchini, onions, and eggplants.

While the standard Robot Coupe comes with two specific plates (R209 and R211 at time of printing), many user applications may require some of the optional plates available with the unit. As an example, a typical salad bar might use:

- R210 2mm (3/32 in.) Slicing plate
- R211 4mm (5/32 in.) Slicing plate
- R209 Medium Grating plate

The R210 plate could be used to slice cucumbers, carrots, celery, etc. Good yield with long shelf life.

The R211 plate could be used to provide half slices of tomatoes, bell peppers, or onions.

The R209 Medium Grating plate would process carrots, cheese, etc.

PLATE HOLDER

R255 Plate Rack

Holds nine plates and is ideal to store your Robot Coupe accessories.

IV. CLEANING/PREVENTIVE MAINTENANCE

(1) CLEANING: Proper cleaning of the machine is one of the most important preventive maintenance measures the user can employ. The high acid content of food can cause harm to the electrical parts contained within the housing. Although a seal isolates these elements from the outside, food juices will tend to seep. If food juices are allowed to collect on the machine over periods of use, erosion of the seal can occur. It is recommended that the machine be cleaned after each operational use.

Correct cleaning procedures are required to assure that damage is not inflicted in the cleaning process. The motor base assembly contains the motor and electrical components.

DO NOT IMMERSE THE MOTOR BASE ASSEMBLY IN WATER!

CLEANING INSTRUCTIONS

ATTACHMENTS: Remove and disassemble all attachments before cleaning. The bowl and continuous feed attachments should be cleaned per the following instructions or as required by local health department regulations.

The bowl, blade, lid, continuous feed attachment, continuous feed lead, pushers, and plates are dishwasher safe. All of the attachments listed above can be washed in a dish machine or three tank system pot sink. Pre-rinse the attachments before washing to remove any bulk food on the parts. A stiff bristle brush or power sprayer faucet attachment is effective in knocking the food out of the crevices as a pre-rinse procedure. The washer should have an industry standard wash, rinse, and sanitization cycle. Allow the parts to air dry after sanitizing and before re-assembly.

NOTE: The high temperatures of dish machines will tend to shorten the life of the plastic and rubber parts. Hand washing using a three pot sink will provide for the longest life of these parts.

Inspect the area around the handle and bowl-switch-rod to ensure they are clean. Use a brush on these areas if necessary.

Cleaning the Blade Assembly

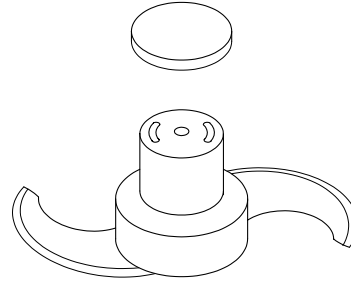

There is a removable cap attached to the top of the S-blade assembly. This cap should be removed when cleaning the blade assembly.

CAUTION: THE BLADES ARE SHARP. WEAR CUT-RESISTANT GLOVES WHEN HANDLING THE BLADE.

The blade cap may be removed by carefully pulling the cap up away from the blade. It may be helpful to pull slightly to the side. The cap is held in place by small plastic clips molded into the cap which snap into the body of the blade assembly. If the cap is difficult to remove, you can use a small diameter rod or screwdriver inserted through the bottom side of the blade assembly to knock out the cap using a quick sharp impact. Again, use caution when handling the blade.

Cleaning: Clean the blade according to local Health Department regulations. It may be necessary to pre wash the blade with a power head sprayer followed by the use of a small round brush to remove any remaining residue. Typical cleaning instructions may include the following:

Dishwasher: Clean the blade assembly in a commercial dish machine by removing the blade cap and placing it flat on a wash tray or in a small parts holder, it could otherwise be washed out of the rack. The dish machine should have a standard wash, rinse, and sanitizing cycle.

Pot Sink: The blade may also be cleaned using the 3 sink method of wash, rinse, and sanitize. Remove the blade cap, and wash each item separately. The sanitization sink should include a minimum of 200 PPM chlorine solution or other approved sanitizing agent. The use of a small brush will assist in removing food particles from around the blade and inside the hub. Allow the parts to air dry laying flat on a drying tray.

Autoclave: The blade assembly will withstand cleaning in an autoclave system with temperatures less than 210 degrees C. However, it will reduce the life of the blade as compared to other sanitizing methods.

MOTOR BASE: Cleaning of the motor base assembly must be done with care: **First unplug the unit.** A sponging with a cloth lightly soaked (not dripping) in a mild detergent is acceptable, making sure the water is not permitted to penetrate the shaft seal or around the switches. Clean around the shaft seal with a small brush, taking care to remove all food. Do not forget to clean the motor shaft. Rinse the motor base first using a cloth lightly dampened (not dripping) with water, then with a sanitizing solution, and dry the machine with a soft cloth removing all liquids from seal areas.

(2) PREVENTIVE MAINTENANCE CHECKS

While your Robot Coupe is a ruggedly constructed machine, overall handling should be accomplished with a sense of use rather than abuse. Reasonable care should be exercised. While the machine is reasonably portable, care should be taken not to drop it. Equally, caution should be exercised in handling all the parts to assure they are not damaged.

An examination should be made periodically to assure that a seal against liquids is being maintained around the motor shaft. With proper care, and depending on use, the seal should last for a year or more. However, it can and should be replaced whenever wear or erosion is noted, or minimally once per year. It is recommended that the seal be replaced by an authorized repair agency.

Blades should be kept sharp. It is not necessary to have a razor edge however they will need sharpening periodically. Replacement of the dull blades or plates is recommended.

(3) CARE: Your Robot Coupe is a piece of kitchen equipment and like all other kitchen equipment, care and caution should be used when operating. Although training requirements are minimal, only responsible individuals familiar with this operation manual should be allowed to operate your Robot Coupe.

In general, the best preventive measures that can be applied are close adherence to the assembly, operation, cleaning, and handling instructions, common sense and regular maintenance.

TROUBLE SHOOTING AIDS: The following sections indicate potential problems and the correct solution which should be implemented by the user. Problems which extend beyond these will require an experienced serviceman. A list of the authorized agencies is supplied.

V. TROUBLE SHOOTING AIDS

- A. Unit does not start when assembled correctly:
 - 1. Pull plug and try another outlet
 - 2. Make sure bowl lid or continuous feed lead is in the proper position with the ramp fully pushed to the right, engaging the safety mechanism.
 - 3. Check the safety switch pin. It will break if the attachment cover is not removed before the attachment.
- B. Continuous feed lead will not fit flush with continuous feed attachment:
 - 1. Processing plate is not in its proper position.
 - 2. Rim of plate should be level with upper edge of motor base.
- C. Unit stops during processing:
 - 1. Turn unit off, and unplug machine
 - 2. Remove continuous feed lead
 - 3. Remove cutting plate
 - 4. Remove product being processed from inside of machine and continuous feed lead
 - 5. Reassemble unit
- D. If unit does not operate after following above:
 - 1. Check outlet for current (Breaker or Fuse)
 - 2. Try unit again
 - 3. Call local authorized service agency.
- E. Unit starts to spark or smoke:
 - 1. Turn unit off, unplug it, call local authorized service agency.
- F. Unit makes grinding noise:
 - 1. Turn unit off, disassemble, check continuous feed lead and processing plate to see if they have been rubbing together (small pieces of plastic would be present).
 - 2. If this was the case, the processing plate was not fully seated. Check for food particles inside stem of processing plate.
 - 3. Replace the plate-insuring that it is fully seated. Make sure there are not food particles on the motor shaft.
 - 4. If noise continues, turn unit off and remove processing plate. Assemble unit without plate and turn unit on. If no noise—processing plate may be bent or warped. Try another plate. If noise persists, call your local factory authorized service agency.
- G. Cucumbers coming out with torn skins and/or with seeds knocked out:
 - 1. Cutting plate is dull and must be changed.

NOTE: Cucumber condition before processing should be considered.

- H. Carrots are watery after grating:
 - 1. Grating plate is dull and should be replaced.
- I. Cheese forms balls instead of shreds:
 - 1. Warm cheese
 - 2. Grating plate is dull and should be replaced.
- J. Machine becomes jammed while processing:
 - 1. Turn unit OFF, and unplug machine. Remove continuous feed lead and remove remnants of product being processed. **Put on a pair of cut-resistant gloves** and try to turn the plate manually in a counterclockwise direction. CAUTION: This may be very hard to do. As soon as you feel the plate slip, you will be able to reassemble the unit and continue processing. If unit jams again, repeat above until you get the plate to slip. Now, remove and clean the plate. Before reassembling, make sure:
 - a. Motor shaft is clean.
 - b. Plate is fully seated on motor shaft.
 - 2. If jamming is too tight to loosen by hand, contact service agency.

CAUTION: IT IS ADVISABLE TO KEEP THE MACHINE UNPLUGGED WHILE CLEANING OR SERVICING.

VI. SERVICE INFORMATION/ SERVICE AGENCY LIST

Your Robot Coupe has a one year limited warranty against defects in parts and workmanship (Check the warranty page within this manual for additional information and/or coverage). Should the unit require service, check with your distributor to see where local service is available. If not or if you wish your unit to be serviced at the factory, call for a return merchandise authorization (RMA) number, and upon receipt of same; ship it PREPAID and insured to our factory address.

Robot Coupe USA, Inc. Service Dept.
Phone: 1-800-824-1646
601-898-8411

Model R2N and R2N Ultra with Emerson motor R239D

R2N Serial Numbers: 244xxxxx03 & 246xxxxx03

1/2 HP, 115 V, 60 Hz, 1725 RPM 6.8 Amp

R2N Ultra Serial Numbers: 245xxxxx03 & 247xxxxx03

1/2 HP, 115 V, 60 Hz, 1725 RPM 6.8 Amp

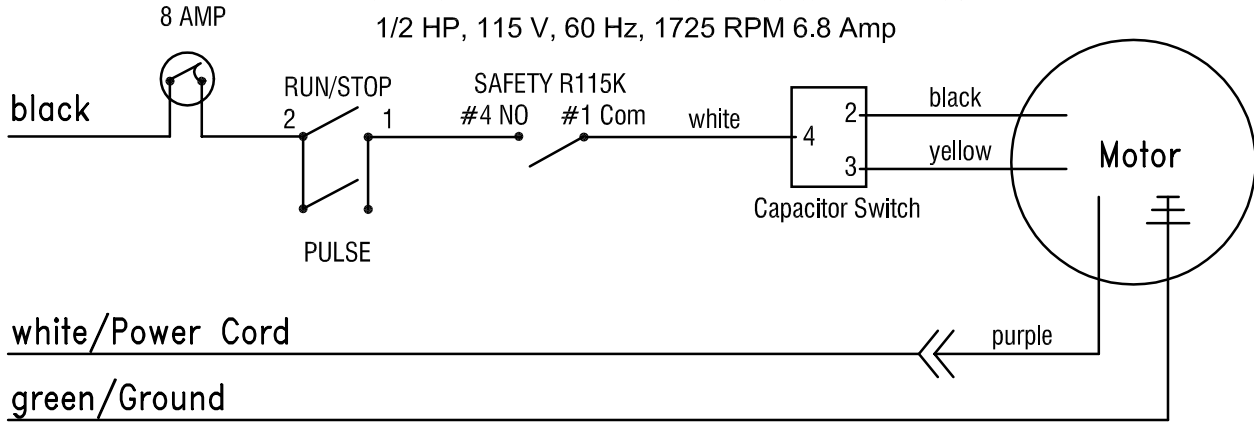

Model R2N and R2N Ultra with A. O. Smith / Magnetek Motor R239

R2N Serial Numbers: 244xxxxx03 & 246xxxxx03

1/2 HP, 115 V, 60 Hz, 1725 RPM 6.8 Amp

R2N Ultra Serial Numbers: 245xxxxx03 & 247xxxxx03

1/2 HP, 115 V, 60 Hz, 1725 RPM 6.8 Amp

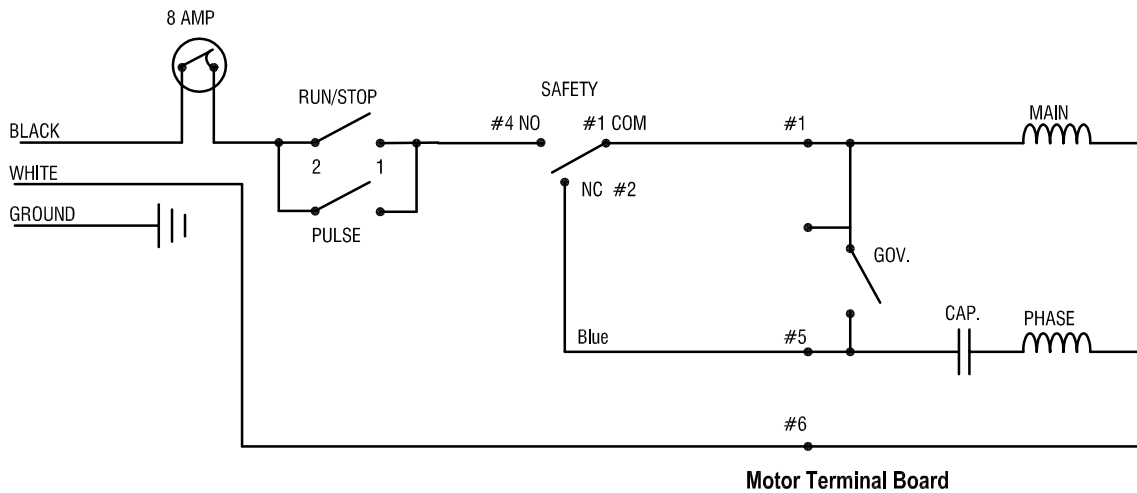

robot coupe® U.S.A. Inc.
 Phone: 1-800-824-1646
 Fax: 601-898-9134
 email: info@robotcoupeusa.com

R2N (3 Quart)

Serial Numbers-246xxxx03
 1-Speed, 120 Volt, 1 Phase, 60Hz., 1/2 HP.
 1725 RPM, 7 Amps

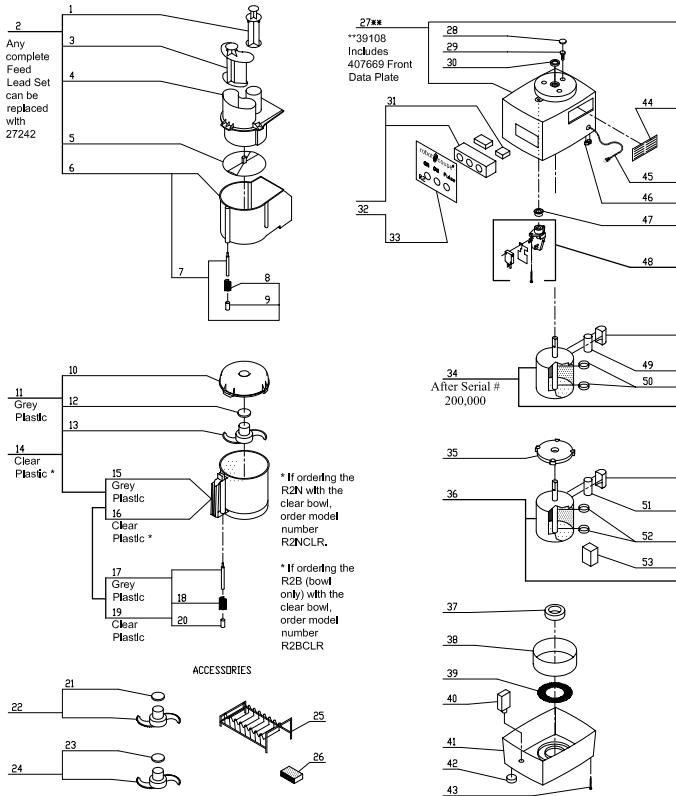
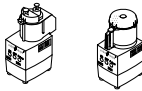

PRICES AND OTHER INFORMATION SUBJECT TO CHANGE WITHOUT NOTICE

MODEL		Serial Numbers 246xxxx03
Indexes	Part #	Description
1	103281	(B) Small Pusher
2	27242	*(B) R2N Cont. Feed Kit, Gray
3	103280	(B) Large Pusher
4	118592	(B) R2 Cont Feed Lead, Gray (replaces white)
5	103288	(B) Discharge Plate
6	102699	(B) R2N/U Cont. Feed Attach, Gray (replaces white)
7	R242	Pin Assy for Plastic Bowl
8	R1776	Spring
9	Number NA	Description NA
10	R204	Cutter Bowl Lid
11	27239	*(B) R2N Bowl Kit 3qt, Gray
12	R3030	Cap Only, R301 S. Blade
13	R203	* Blade
14	27240	*(B) R2N Clear Bowl Kit, 3qt.
15	112204	(B) R2N Gray Bowl Only, 3qt
16	112203	(B) R2N Clear Bowl Only, 3qt
17	39103	(B) Pin Assy, R2N 3qt Gray
18	R1776	Spring
19	39077	(B) Pin Assy R2N 3qt. Clear Bowl
20	Number NA	Description NA
21	R3030	Cap Only, R301 S. Blade
22	R203D	* S Blade, Fine Serration
23	R3030	Cap Only, R301 S. Blade
24	R203E	* S. Blade Coarse Serrations
25	R255	* Plate Rack
26	R248	Honing Stone
27	39108	(B) R2N Motor Support, 3qt
28	R262	Screw Cover
29	R232A	Screw (Motor - MS)
30	R118	Motor Support Seal
31	R274	Pulse Switch
32	39106	(B) R2N Switch Assy, 3qt
33	407669	(B) Frant Data Plate R2N, 3qt
34	R239	Mtr F/C 1/3HP 115V/60HZ
35	R239D.3	Adapter Plate, EM
36	R239D	Motor, EM
37	R265	Bottom Cushion Bushing
38	R278A	Baffle
39	R277A	Screen Kit
40	R286	8amp Breaker (R2ANN)
41	104124	(B) R2 Base, Gray
42	R101	Foot
43	R119	Screw (Base-MS 3.9x19)
44	R276A	Louvre (mil) W/Rivits
45	R240	Cord with Plug
46	R104	Strain Relief
47	R225	Rubber O Ring (Black)
48	R115K	Safety Switch Assembly
49	R222	Capacitor F/C Mtr (R2N)
50	R237	6203 Bearing R2 Top/Btm
51	R239D.2	Capacitor
52	R237	6203 Bearing R2 Top/Btm
53	R239D.1	Relay

robot coupe® U.S.A. Inc.
 Phone: 1-800-824-1646
 Fax: 601-898-9134
 email: info@robotcoupeusa.com

R2N Ultra (3 Quart)

Serial Number Series- 247xxxxx03
 1- Speed, 120 Volt, 1 Phase, 60Hz., 1 HP.
 1725 RPM, 7 Amps

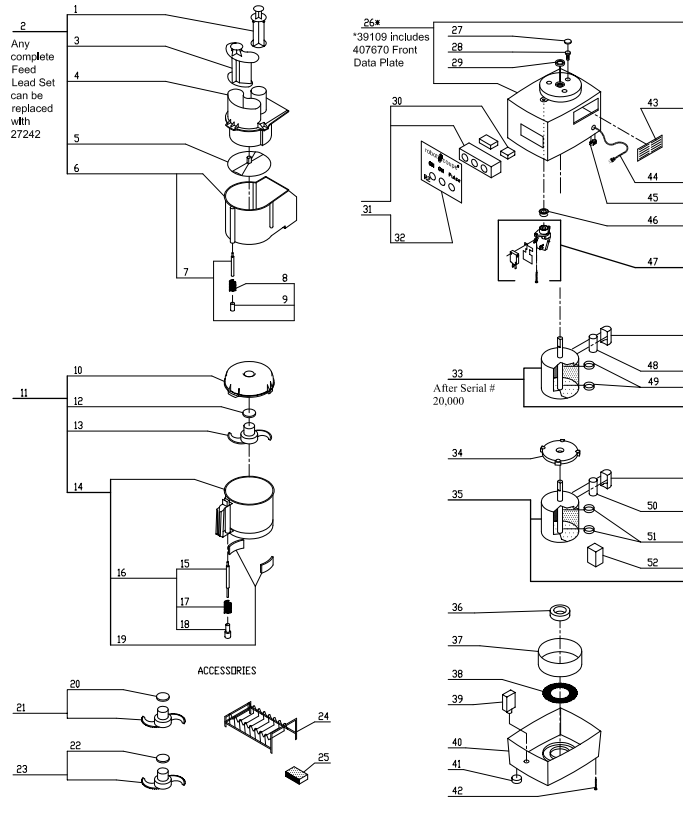
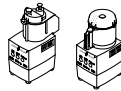

PRICES AND OTHER INFORMATION SUBJECT TO CHANGE WITHOUT NOTICE

MODEL		Serial Numbers 247xxxx03
Indexes	Part #	Description
1	103281	(B) Small Pusher
2	27242	* (B) R2N Cont Feed Kit, Gray
3	103280	(B) Large Pusher
4	118592	(B) R2 Cont Feed Lead, Gray (replaces white)
5	103288	(B) Discharge Plate
6	102699	(B) R2N/U Cont. Feed Attach, Gray (replaces white)
7	R242	Pin Assy for Plastic Bowl
8	R1776	Spring
9	Number NA	Description NA
10	R204	Cutter Bowl Lid
11	27243	* (B) R2U S.S. Bowl Kit, 3qt
12	R3030	Cap Only, R301 S. Blade
13	R203	* Blade
14	104099	(B) R2U S.S. Bowl Only, 3qt
15	104098	(B) Pin, 3qt S.S. Bowl
16	Number NA	Description NA
17	R1776	Spring
18	104050	(B) Retaining Nut
19	R289	Lckg Bush Set w/Screws
20	R3030	Cap Only, R301 S. Blade
21	R203D	* S Blade, Fine Serration
22	R3030	Cap Only, R301 S. Blade
23	R203E	* S. Blade Coarse Serrations
24	R255	* Plate Rack
25	R248	Honing Stone
26	39109	(B) R2U Motor Support, 3qt
27	R262	Screw Cover
28	R232A	Screw (Motor - MS)
29	R118	Motor Support Seal
30	R274	Pulse Switch
31	39107	(B) R2U Switch Assy, 3qt
32	407670	(B) Front Data Plate R2U, 3qt
33	R239	Mtr F/C 1/3HP 115V/60HZ
34	R239D.3	Adapter Plate, EM
35	R239D	Motor, EM
36	R265	Bottom Cushion Bushing
37	R278A	Baffle
38	R277A	Screen Kit
39	R286	8amp Breaker (R2ANN)
40	104124	(B) R2 Base, Gray
41	R101	Foot
42	R119	Screw (Base-MS 3.9x19)
43	R276A	Louvre (mtl) W/Rivits
44	R240	Cord with Plug
45	R104	Strain Relief
46	R225	Rubber O Ring (Black)
47	R115K	Safety Switch Assembly
48	R222	Capacitor F/C Mtr (R2N)
49	R237	6203 Bearing R2 Top/Btm
50	R239D.2	Capacitor
51	R237	6203 Bearing R2 Top/Btm
52	R239D.1	Relay

ROBOT COUPE U.S.A. INC. LIMITED WARRANTY

R2 SERIES ONE YEAR LIMITED WARRANTY AND EXTENDED THREE-YEAR MOTOR LIMITED WARRANTY

This LIMITED WARRANTY is to the original purchaser only against defects in material and/or workmanship, and includes labor for replacement of defective parts, provided repairs are performed by a Robot Coupe Authorized Service Agency (see attached list). The CUSTOMER must inform the Service Agency of the possibility of warranty coverage and provide a copy of the dated sales or delivery receipt BEFORE WARRANTY REPAIRS ARE BEGUN. Replacement parts and accessories are warranted for ninety (90) days from the date of purchase when purchased separately and will be verified by a dated sales receipt OR packing list, which list that item. All parts or accessories replaced under warranty are the property of Robot Coupe and must be returned to the Service Agency.

The motor of your new R2 series machine, which serial number begins with 244xxxxxx or 245xxxxxx is warranted an additional two (2) years against defects for a total of three (3) year motor warranty. Robot Coupe will replace any motor and shaft seal only which fails due to mechanical malfunction not including seal and bearing failure. The additional two (2) year motor warranty does NOT include labor to install, shipping charges, travel or mileage charges, or other incidental charges incurred during motor replacement. The machine purchase date must be verified with a dated copy of the purchase invoice from your selling dealer.

Robot Coupe USA designs many attachments and accessories for use on specific models and series of machines. THE USE OF PARTS, ATTACHMENTS, OR ACCESSORIES OTHER THAN THOSE OFFERED FOR SALE BY ROBOT COUPE U.S.A. Inc. AND DESIGNED FOR USE ON YOUR SPECIFIC MODEL AND SERIES WILL VOID YOUR WARRANTY.

THE FOLLOWING ARE NOT COVERED BY THE ROBOT COUPE LIMITED WARRANTY

1. Damage caused by abuse, misuse, dropping, or other similar incidental damage caused by or as a result of failure to follow assembly, operating, cleaning, and user maintenance or storage instructions.
2. Labor to sharpen and/or parts to replace knife assemblies or blades which have become dull, chipped, or worn due to normal use.
3. Material or labor to renew or repair scratched, stained, chipped, dented or discolored surfaces, blades, knives, attachments, or accessories.
4. Transportation charges to or from an authorized service agency for repairs of a machine designated as CARRY IN SERVICE . The R2 series are warranted only for carry in service.
5. Labor charges to install or test attachments or accessories (i.e. bowls, cutting plates, blades, attachments) which are replaced for any reason.
6. **SHIPPING DAMAGE IS NOT COVERED BY WARRANTY.** Visible and hidden damages are the responsibility of the freight carrier. The consignee or receiver must file a damage claim promptly against the carrier, or upon discovery in the case of hidden damage. KEEP ALL ORIGINAL CONTAINERS AND PACKING MATERIAL FOR CARRIER INSPECTION.

Robot Coupe U.S.A., Inc., Robot Coupe S.A., or any of their affiliates, distributors, officers, directors, agents, employees, or insurers will not be obligated for consequential or other damages, losses, or expenses in connection with or by reason of the use of or inability to use the machine for any purpose.

THIS WARRANTY IS GIVEN EXPRESSLY AND IN LIEU OF ALL OTHER WARRANTIES EXPRESSED OR IMPLIED, FOR MERCHANTABILITY AND FOR FITNESS TOWARD A PARTICULAR PURPOSE AND CONSTITUTES THE ONLY WARRANTY MADE BY ROBOT COUPE U.S.A., Inc.