



**T&S BRASS AND BRONZE WORKS, INC.**  
 2 Saddleback Cove / P.O. Box 1088  
 Travelers Rest, SC 29690

Model No.  
**B-0580**

Item No.

Travelers Rest, SC: 800-476-4103 • Simi Valley, CA: 800-423-0150 • Fax: 864-834-3518 • www.tsbrass.com

This Space for Architect/Engineer Approval

Job Name \_\_\_\_\_ Date \_\_\_\_\_

Model Specified \_\_\_\_\_ Quantity \_\_\_\_\_

Customer/Wholesaler \_\_\_\_\_

Contractor \_\_\_\_\_

Architect/Engineer \_\_\_\_\_

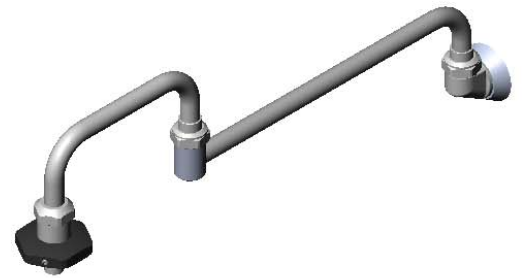

Heat Resistant "On-Off" Handle

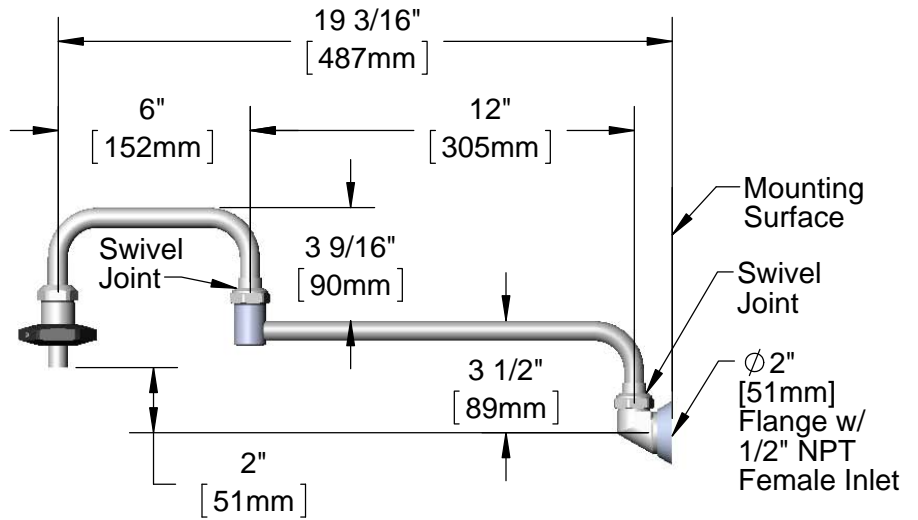

Product Specifications:  
 Pot Filler w/ 18" Double Joint Swing Nozzle, Heat Resistant Handle,  
 1/2" NPT Female Inlet

Product Compliance:  
 ASME A112.18.1 / CSA B125.1  
 NSF 61 - Section 9  
 NSF 372 (Low Lead Content)



# T&S BRASS AND BRONZE WORKS, INC.

2 Saddleback Cove / P.O. Box 1088  
Travelers Rest, SC 29690

Model No.

**B-0580**

Item No.

Travelers Rest, SC: 800-476-4103 • Simi Valley, CA: 800-423-0150 • Fax: 864-834-3518 • www.tsbrass.com

ITEM NO.	SALES NO.	DESCRIPTION
1	002848-40	18" Double Joint Nozzle w/ Heat Resistant Handle
2	002870-40	6" Front Section
3	003426-45	O-Ring
4	001089-45	Seal
5	001498-25	Spout
6	000587-25	Spout Body
7	001126-20	Handle w/ (2) Set Screws
8	000936-45	Handle Set Screw
9	002871-40	12" Back Section
10	035A	Outlet
11	000101-40	Flange
12	011429-45	Swivel Sleeves (2)
13	001074-45	O-Ring
14	009538-45	Swivel Washer

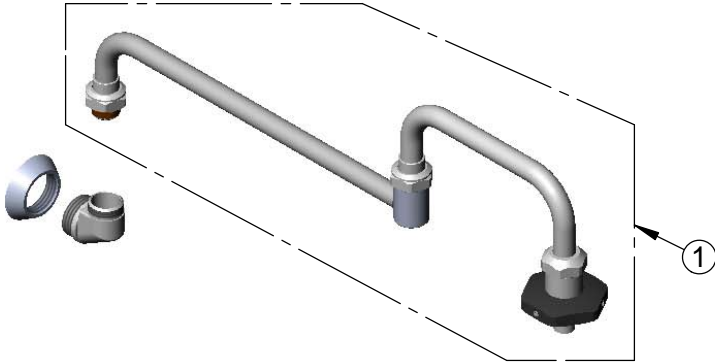

Additional View for Bill Of Material Clarification

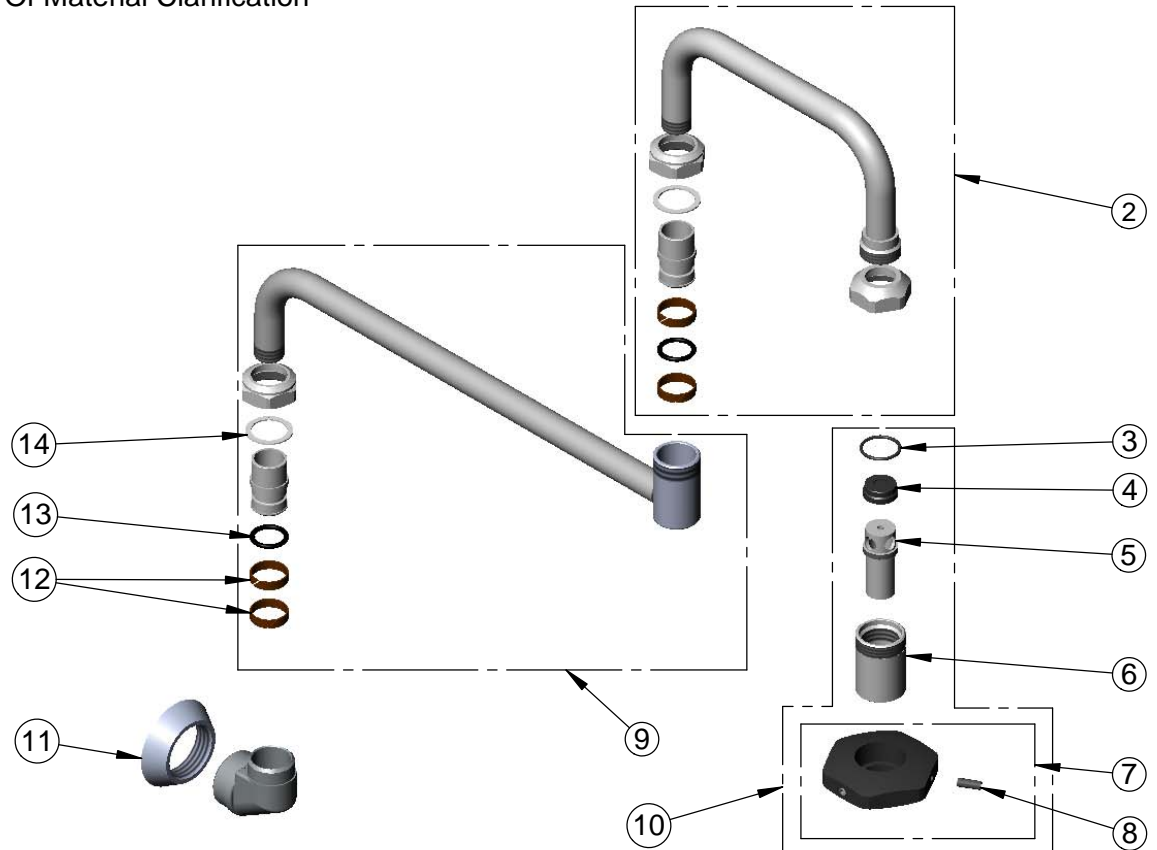

**Product Specifications:**

Pot Filler w/ 18" Double Joint Swing Nozzle, Heat Resistant Handle, 1/2" NPT Female Inlet

**Product Compliance:**

ASME A112.18.1 / CSA B125.1  
NSF 61 - Section 9  
NSF 372 (Low Lead Content)